

Software Design Patterns

Jonathan I. Maletic, Ph.D.
<SDML>
Department of Computer Science
Kent State University

J. Maletic

1

Background₁

- Search for recurring successful designs – emergent designs from practice (via trial and error)
- Supporting higher levels of reuse (i.e., reuse of designs) is quite challenging
- Described in Gama, Helm, Johnson, Vlissides 1995 (i.e., “gang of 4 book”)
- Based on work by Christopher Alexander (an Architect) on building homes, buildings and towns.

J. Maletic

2

Background₂

- Design patterns represent solutions to problems that arise when developing software within a particular context, e.g., problem/solution pairs within a given context
- Describes recurring design structures
- Describes the context of usage

J. Maletic

3

Background₃

- Patterns capture the static and dynamic *structure* and *collaboration* among key participants in software designs
- Especially good for describing how and why to resolve *nonfunctional issues*
- Patterns facilitate reuse of successful software architectures and designs.

J. Maletic

4

Origins of Design Patterns

"Each pattern describes a problem which occurs over and over again in our environment and then describes the core of the solution to that problem, in such a way that you can use this solution a million times over, without ever doing it in the same way twice"

- Christopher Alexander, A Pattern Language, 1977
- Context: City Planning and Building architectures

J. Maletic

5

Elements of Design Patterns

- Design patterns have four essential elements:
 - Pattern name
 - Problem
 - Solution
 - Consequences

J. Maletic

6

Pattern Name

- A handle used to describe:
 - a design problem
 - its solutions
 - its consequences
- Increases design vocabulary
- Makes it possible to design at a higher level of abstraction
- Enhances communication

*"The Hardest part of programming is coming up with good variable [function, and type] names."
J. Maletic*

J. Maletic

7

Problem

- Describes when to apply the pattern
- Explains the problem and its context
- May describe specific design problems and/or object structures
- May contain a list of preconditions that must be met before it makes sense to apply the pattern

J. Maletic

8

Solution

- Describes the elements that make up the
 - design
 - relationships
 - responsibilities
 - collaborations
- Does not describe specific concrete implementation
- Abstract description of design problems and how the pattern solves it

J. Maletic

9

Consequences

- Results and trade-offs of applying the pattern
- Critical for:
 - evaluating design alternatives
 - understanding costs
 - understanding benefits of applying the pattern
- Includes the impacts of a pattern on a system's:
 - flexibility
 - extensibility
 - portability

J. Maletic

10

Design Patterns are NOT

- Designs that can be encoded in classes and reused as is (i.e., linked lists, hash tables)
- Complex domain-specific designs (for an entire application or subsystem)
- They are:
 - "Descriptions of communicating objects and classes that are customized to solve a general design problem in a particular context."

J. Maletic

11

Where They are Used

- Object-Oriented programming languages [and paradigm] are more amenable to implementing design patterns
- Procedural languages: need to define
 - *Inheritance*
 - *Polymorphism*
 - *Encapsulation*

J. Maletic

12

Façade Pattern

- Intent
 - Provide a unified interface to a set of interfaces in a subsystem.
 - Façade defines a higher-level interface that makes the subsystem easier to use

J. Maletic

16

Structure

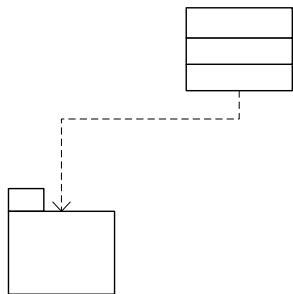

J. Maletic

17

Design Pattern Descriptions

- **Name and Classification:** Essence of pattern
- **Intent:** What it does, its rationale, its context
- **AKA:** Other well-known names
- **Motivation:** Scenario illustrates a design problem
- **Applicability:** Situations where pattern can be applied
- **Structure:** Class and interaction diagrams
- **Participants:** Objects/classes and their responsibilities
- **Collaborations:** How participants collaborate
- **Consequences:** Trade-offs and results
- **Implementation:** Pitfalls, hints, techniques, etc.
- **Sample Code**
- **Known Uses:** Examples of pattern in real systems
- **Related Patterns:** Closely related patterns

J. Maletic

18

Facade

+interface()

Example: Stock Quote Service

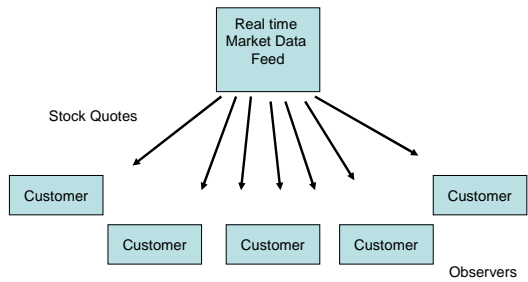

J. Maletic

19

Observer Pattern

- Intent:
 - Define a one-to-many dependency between objects so that when one object changes state, all its dependents are notified and updated automatically
- Key forces:
 - There may be many observers
 - Each observer may react differently to the same notification
 - The subject should be as decoupled as possible from the observers to allow observers to change independently of the subject

J. Maletic

20

Structure of Observer Pattern

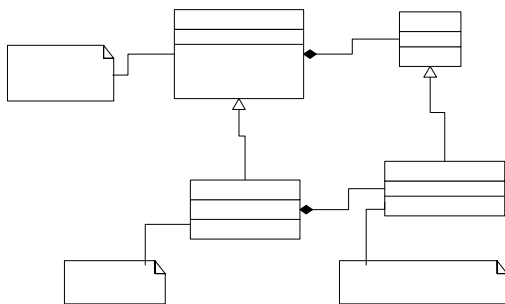

J. Maletic

21

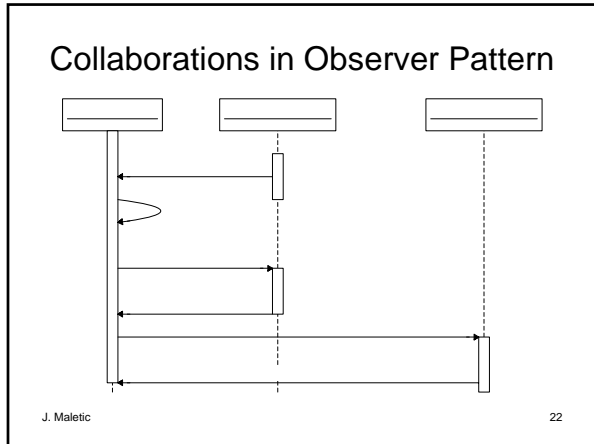

S1 : ConcreteSubject

obs1 : ConcreteObserver

obs2 : ConcreteObserver

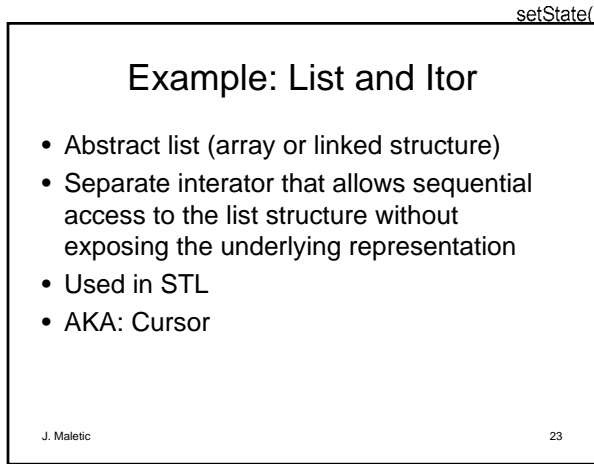

setState()

update()

getState()

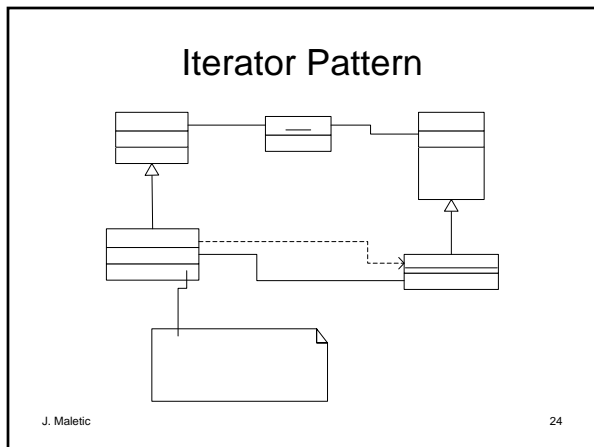

Types of Patterns

- **Creational patterns:**
 - Deal with initializing and configuring classes and objects
- **Structural patterns:**
 - Deal with decoupling interface and implementation of classes and objects
 - Composition of classes or objects
- **Behavioral patterns:**
 - Deal with dynamic interactions among societies of classes and objects
 - How they distribute responsibility

J. Maletic

25

Creational Patterns

- **Abstract Factory:**
 - Factory for building related objects
- **Builder:**
 - Factory for building complex objects incrementally
- **Factory Method:**
 - Method in a derived class creates associates
- **Prototype:**
 - Factory for cloning new instances from a prototype
- **Singleton:**
 - Factory for a singular (sole) instance

J. Maletic

26

Structural Patterns

- **Adapter:**
 - Translator adapts a server interface for a client
- **Bridge:**
 - Abstraction for binding one of many implementations
- **Composite:**
 - Structure for building recursive aggregations
- **Decorator:**
 - Decorator extends an object transparently
- **Facade:**
 - Simplifies the interface for a subsystem
- **Flyweight:**
 - Many fine-grained objects shared efficiently.
- **Proxy:**
 - One object approximates another

J. Maletic

27

Behavioral Patterns

- **Chain of Responsibility:**
 - Request delegated to the responsible service provider
- **Command:**
 - Request is first-class object
- **Iterator:**
 - Aggregate elements are accessed sequentially
- **Interpreter:**
 - Language interpreter for a small grammar
- **Mediator:**
 - Coordinates interactions between its associates
- **Memento:**
 - Snapshot captures and restores object states privately

J. Maletic

28

Behavioral Patterns (cont.)

- **Observer:**
 - Dependents update automatically when subject changes
- **State:**
 - Object whose behavior depends on its state
- **Strategy:**
 - Abstraction for selecting one of many algorithms
- **Template Method:**
 - Algorithm with some steps supplied by a derived class
- **Visitor:**
 - Operations applied to elements of a heterogeneous object structure

J. Maletic

29

Design Pattern Space

		Purpose		
		Creational	Structural	Behavioral
Scope	Class	Factory method	Adapter (class)	Interpreter Template method
	Object	Abstract factory Builder Prototype Singleton	Adapter (object) Bridge Composite Decorator Façade Flyweight Proxy	Chain of responsibility Command Iterator Mediator Memento Observer State Strategy Visitor

J. Maletic

30

Categorization Terms

- Scope is the domain over which a pattern applies
 - Class Scope: relationships between base classes and their subclasses (static semantics)
 - Object Scope: relationships between peer objects
- Some patterns apply to both scopes.

J. Maletic

31

Class:: Creational

- Abstracts how objects are instantiated
- Hides specifics of the creation process
- May want to delay specifying a class name explicitly when instantiating an object
- Just want a specific protocol

J. Maletic

32

Example

- Use **Factory Method** to instantiate members in base classes with objects created by subclasses
- Abstract *Application* class: create application-specific documents conforming to a particular *Document* type
- Application instantiates these *Document* objects by calling the factory method *CreateDocument*
- Method is overridden in classes derived from *Application*
- Subclass *DrawApplication* overrides *CreateDocument* to return a *DrawDocument* object

J. Maletic

33

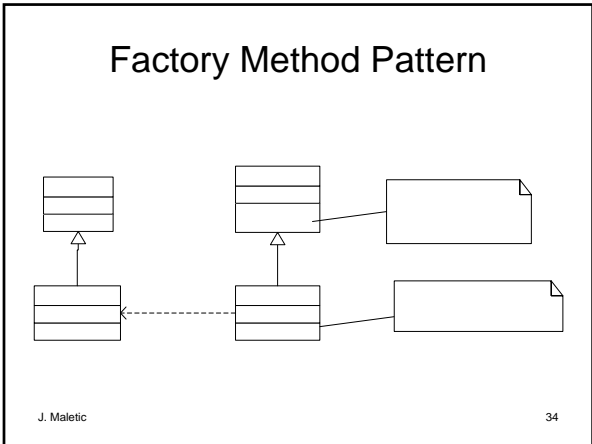

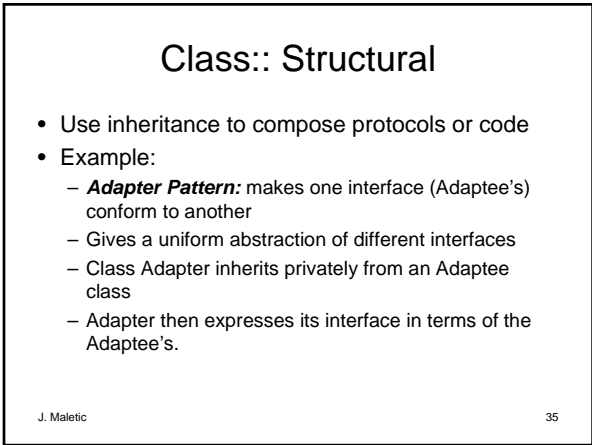

```

Creator
{
+FactoryMethod()    product=FactoryMethod()
+Operation1()      }
  
```

```

ConcreteCreator
{
Return new ConcreteProduct()
}
+FactoryMethod()
  
```

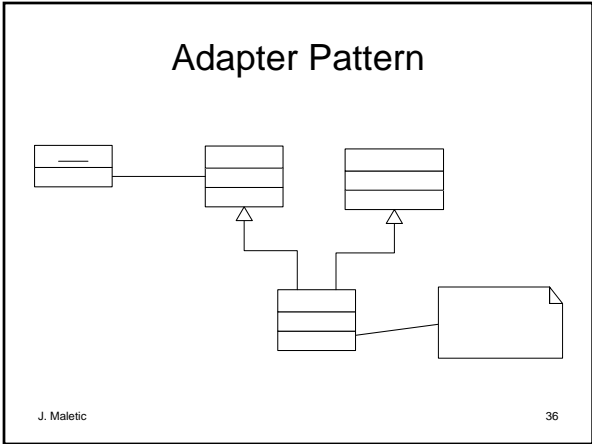

Class:: Behavioral

- Captures how classes cooperate with their subclasses to satisfy semantics.

Example:

- **Template Method:** defines algorithms step by step.
- Each step can invoke an abstract method (that must be defined by the subclass) or a base method.
- Subclass must implement specific behavior to provide required services

J. Maletic

37

Template Method Pattern

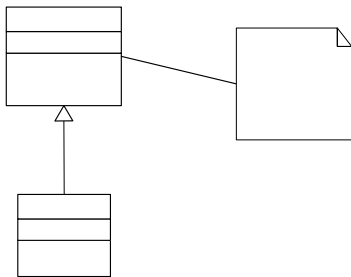

J. Maletic

38

Object Scope

- Object Patterns all apply various forms of non-recursive object composition.
- Object Composition: most powerful form of reuse
- Reuse of a collection of objects is better achieved through variations of their composition, rather than through subclassing.

J. Maletic

39

AbstractClass

```
+TemplateMethod()  
+operation1()  
+operation2()
```

```
{  
  operation1();  
  ...  
  operation2();  
  ....  
}
```

Object:: Creational

- Abstracts how sets of objects are created

Example:

- **Abstract Factory:** create "product" objects through generic interface
 - Subclasses may manufacture specialized versions or compositions of objects as allowed by this generic interface
- User Interface Toolkit: 2 types of scroll bars (Motif and Open Look)
 - Don't want to hard-code specific one; an environment variable decides
- Class Kit:
 - Encapsulates scroll bar creation (and other UI entities);
 - An abstract factory that abstracts the specific type of scroll bar to instantiate
 - Subclasses of Kit refine operations in the protocol to return specialized types of scroll bars.
 - Subclasses MotifKit and OpenLookKit each have scroll bar operation.

J. Maletic

40

Abstract Factory Pattern

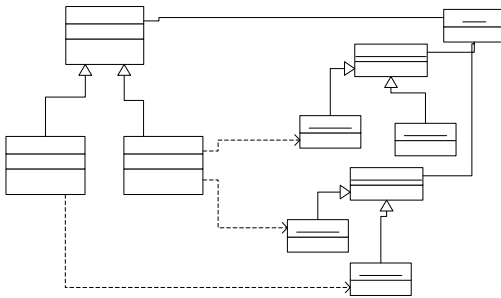

J. Maletic

41

Object:: Structural

- Describe ways to assemble objects to realize new functionality
 - Added flexibility inherent in object composition due to ability to change composition at run-time
 - not possible with static class composition
- Example:
 - **Proxy:** acts as convenient surrogate or placeholder for another object.
 - Remote Proxy: local representative for object in a different address space
 - Virtual Proxy: represent large object that should be loaded on demand
 - Protected Proxy: protect access to the original object

J. Maletic

42

AbstractFactory

+CreateProductA()
+CreateProductB()

Client

AbstractProductA

«instance»

ProductA

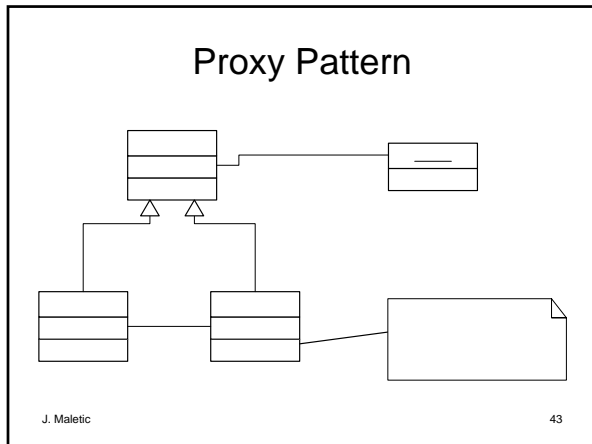

Subject

Client

Object:: Structural - example

- Implement ODBC
- Could be done with an adaptor unless you need to extend both the interface and implementation
- Or if you know the implementation will change often
- The implementation class defines what types of things need to be supported

J. Maletic 44

```

Proxy
{
    request()
    {
        realSubject->request();
        ...
    }
}

```

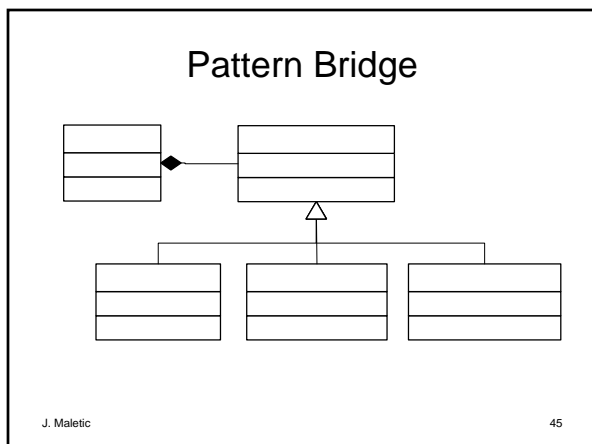

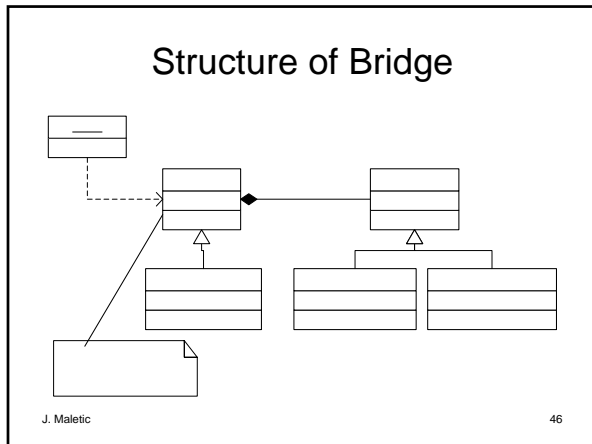

Client

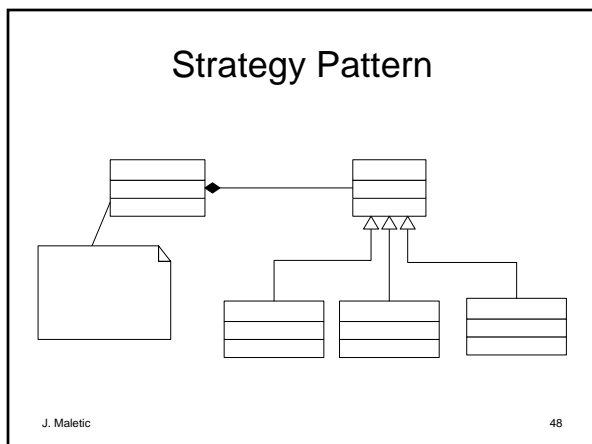
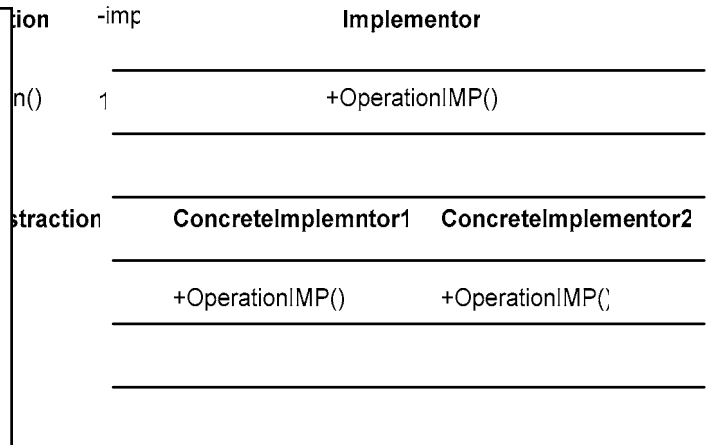
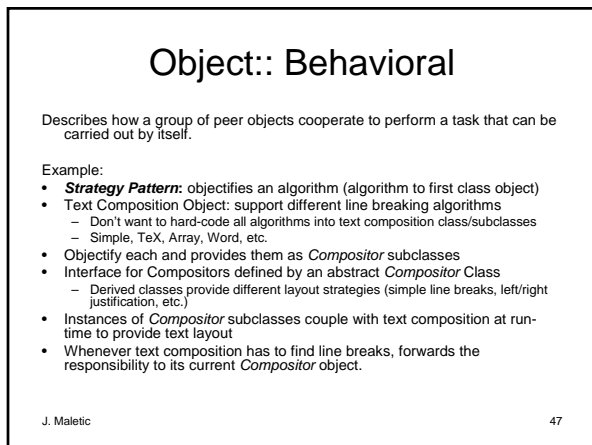

When to Use Patterns

- Solutions to problems that recur with variations
 - No need for reuse if problem only arises in one context
- Solutions that require several steps:
 - Not all problems need all steps
 - Patterns can be overkill if solution is a simple linear set of instructions
- Solutions where the solver is more interested in the existence of the solution than its complete derivation
 - Patterns leave out too much to be useful to someone who really wants to understand
 - They can be a temporary bridge

J. Maletic

49

What Makes it a Pattern?

- A Pattern must:
 - Solve a problem and be useful
 - Have a context and can describe where the solution can be used
 - Recur in relevant situations
 - Provide sufficient understanding to tailor the solution
 - Have a name and be referenced consistently

J. Maletic

50

Benefits of Design Patterns

- Design patterns enable large-scale reuse of software architectures and also help document systems
- Patterns explicitly capture expert knowledge and design tradeoffs and make it more widely available
- Patterns help improve developer communication
- Pattern names form a common vocabulary
- Patterns help ease the transition to OO technology

J. Maletic

51

Drawbacks to Design Patterns

- Patterns do not lead to direct code reuse
- Patterns are deceptively simple
- Teams may suffer from pattern overload
- Patterns are validated by experience and discussion rather than by automated testing
- Integrating patterns into a software development process is a human-intensive activity.

J. Maletic

52

Suggestions for Effective Use

- Do not recast everything as a pattern
 - Instead, develop strategic domain patterns and reuse existing tactical patterns
- Institutionalize rewards for developing patterns
- Directly involve pattern authors with application developers and domain experts
- Clearly document when patterns apply and do not apply
- Manage expectations carefully.

J. Maletic

53

References

- Gama, Helm, Johnson, Vlissides, *Design Patterns Elements of Reusable Object-Oriented Software*, Addison Wesley, 1995
- B. Cheng – Michigan State University

J. Maletic

54

Web Resources

- <http://www.dofactory.com/>
- <http://hillside.net/patterns/>

J. Maletic

55
