

What is a Distributed System?

■ From various textbooks:

- “A distributed system is a collection of independent computers that appear to the users of the system as a single computer.”
- “A distributed system consists of a collection of autonomous computers linked to a computer network and equipped with distributed system software.”
- “A distributed system is a collection of processors that do not share memory or a clock.”
- “Distributed systems is a term used to define a wide range of computer systems from a weakly-coupled system such as wide area networks, to very strongly coupled systems such as multiprocessor systems.”

1

Spring 1999, Lecture 01

What is a Distributed System? (cont.)

- A *distributed system* is a set of physically separate processors connected by one or more communication links

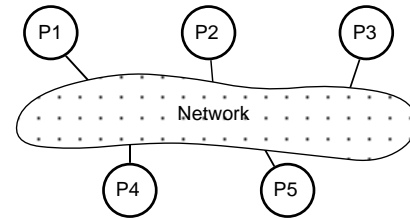

- Workstation = computer = machine = processor = host = site = node
- Is every system with >2 computers a distributed system??
 - Email, ftp, telnet, world-wide-web
 - Network printer access, network file access, network file backup
 - We don't usually consider these to be distributed systems...

2

Spring 1999, Lecture 01

Two Taxonomies for Classifying Computer Systems

■ Michael Flynn (1966)

- SISD — single instruction, single data
- SIMD — single instruction, multiple data
- MISD — multiple instruction, single data
- MIMD — multiple instruction, multiple data

■ More recent (Stallings, 1993)

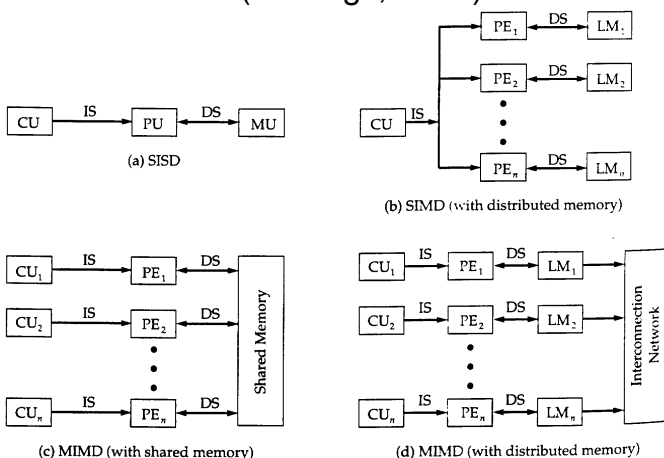

FIGURE 16.16. Alternative Computer Organizations

3

Spring 1999, Lecture 01

Classification of MIMD Architectures

■ Tanenbaum (date?)

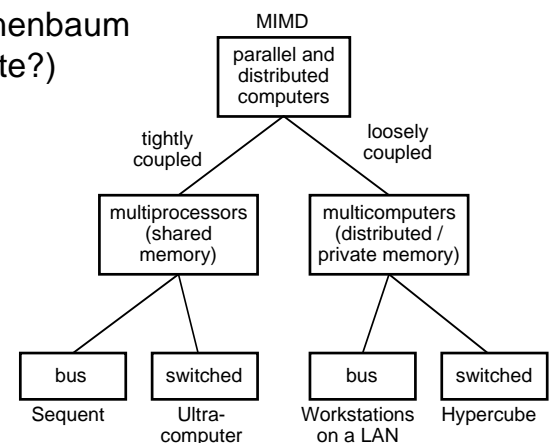

■ Tightly coupled ≈ *parallel processing*

- Processors share clock and memory, run one OS, communicate frequently

■ Loosely coupled ≈ *distributed computing*

- Each processor has its own memory, runs its own OS (?), communicates infrequently

4

Spring 1999, Lecture 01

Classification of Operating Systems

■ Multiprocessor Operating System

- Tightly-coupled software (single OS) running on tightly-coupled hardware
- A process can run on any processor
 - Single ready queue!
- All memory is shared
- File system similar to that on non-distributed systems

■ Network Operating System

- Loosely-coupled hardware
- Loosely-coupled software
 - Each computer runs its own OS
 - User knows which machine he/she is on
- Goal: share resources, provide global (network) file system
- Typical utility programs: rlogin, rcp, telnet, ftp

5

Spring 1999, Lecture 01

Classification of Operating Systems (cont.)

■ “True” Distributed Operating System

- Loosely-coupled hardware
 - No shared memory, but provides the “feel” of a single memory
- Tightly-coupled software
 - One single OS, or at least the feel of one
- Machines are somewhat, but not completely, autonomous

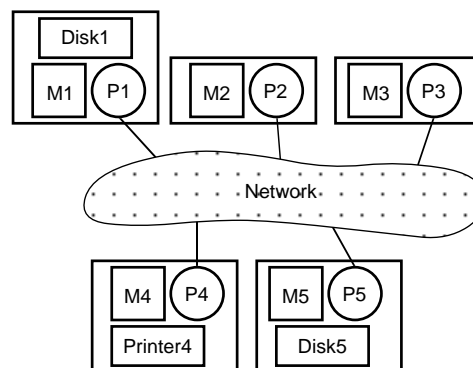

6

Spring 1999, Lecture 01