

Wednesday 22 March 2006

1. Given the two 4-variable Karnaugh maps below, circle the 1's and write the minimized sum of products expression below each map. (16 points)

	┌ A ─┐				
	0	1	1	1	
┌ D ─┐ └ ─┘	1	1	0	0	└ C ─┘ └ ─┘
	1	1	0	0	
	0	1	0	0	
	└ B ─┘				

	┌ A ─┐				
	0	1	1	0	
┌ D ─┐ └ ─┘	1	0	0	1	└ C ─┘ └ ─┘
	1	0	0	1	
	0	0	0	0	
	└ B ─┘				

2. What functionality is provided by an S-R latch? Define its inputs and outputs and what happens for the various input combinations. (10 points)

Name: _____

3. Consider the ALU shown to the right.

a. What functionality is provided by the Decoder? Be specific. (10 points)

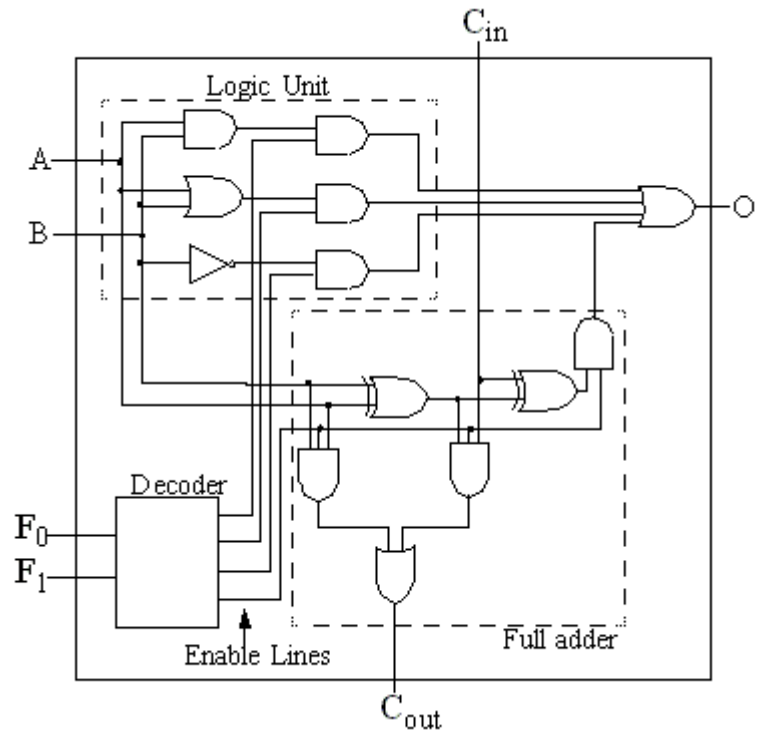

b. The Decoder's Enable Lines connect to AND gates. What functionality is provided by those AND gates? Be specific. (10 points)

Name: _____

4. Consider a digital circuit for a consumer electronic product, which could be implemented using either a full-custom ASIC, standard-cell-based ASIC, or FPLD.

a. Which implementation style has the potential to yield the highest-performance circuit, and why? (7 points)

b. Which has the potential to get the product to market the fastest, and why? (7 points)

5. On the Altera UP1 Education Board, the push buttons are “active low”. What does that mean? (5 points)

Name: _____

6. Consider the following AHDL code fragment:

```
SUBDESIGN mealy
{
  clock, reset, y: INPUT;
  z: OUTPUT ;
}
VARIABLE
  ss: MACHINE WITH STATES (s0, s1, s2, s3);
TABLE
  ss, y => z, ss;
  s0, 0 => 0, s0;
  s0, 1 => 1, s1;
  ...
END TABLE;
```

a. Explain what the two lines enclosed in the box do. Be specific. (10 points)

b. Would the operation of the circuit change if the lines enclosed in the box were interchanged? Explain. (10 points)

Name: _____

7. Consider the following AHDL code fragment from the keypad encoder in Salcic Chapter 5:

```
mux.d[3..0] = col[3..0];  
mux.(b,a) = counter.(qb, qa);  
key_pressed = !mux.y;
```

Explain what this code fragment does. Be specific. (15 points)